

Rev P

O-CEX-0SXXYY-X-E-X-X-10.000 MHz
Precision Ultra Low Phase Noise OCXO in 36x27 mm
“Europack”

Product Data Sheet

Features

- SC-cut crystal
- High Stability
- Low Aging
- Ultra Low Phase Noise
 Extraordinary (E) -91 dBc/Hz at 0.1 Hz
 -123 dBc/Hz at 1 Hz
 -151 dBc/Hz at 10 Hz
 -172 dBc/Hz on the floor
- Sine Wave output +14 dBm TYP

Applications

- Instrumentation
- GPS
- Telecommunication Systems
- Radar
- COTS/Dual use

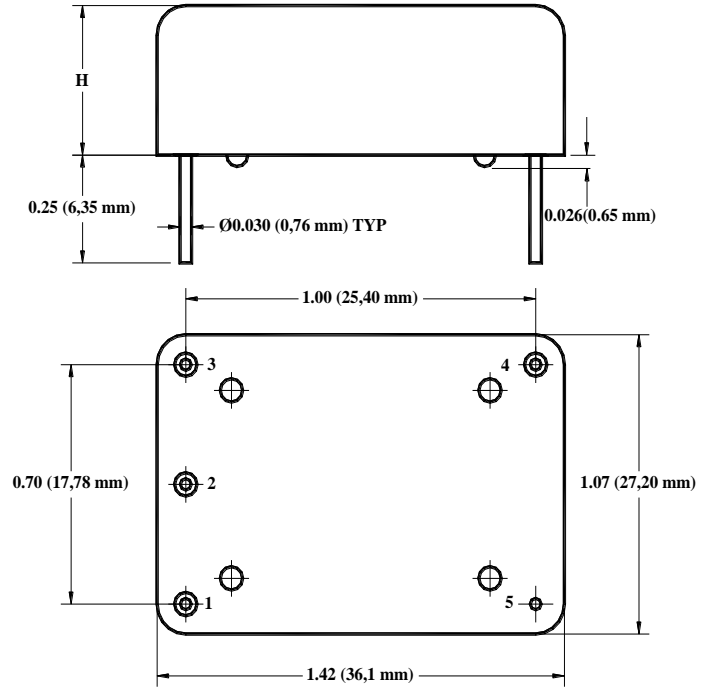

H code	Height, inches (mm) TYP
6	0.63 (16 mm) 7*
7	0.75 (19 mm)
1	1.0 (25.4 mm)

Parameter	Symb	Condition	Min	Typ	Max	Unit	Note
-----------	------	-----------	-----	-----	-----	------	------

Absolute Maximum Ratings

Input Break Down Voltage	V _{cc}	5 V supply	-0.5		5.5	V	
Storage temper.	T _s		-50		90	°C	
Control Voltage	V _c		-1		11	V	Slope option "L"

Electrical (6)

Frequency	F			10.000		MHz		
Frequency stability	$\Delta F/F$	vs. Temp.	From ± 2.0			ppb	See chart below	
		vs. Supply		0.1	0.2	ppb/5% V _{cc}		
		vs. Load			0.5	ppb/5% load var.		
Aging		per day		2E-10			after 30 days	
		per year, first year		2E-8				
		second year		1E-8				
		10 years		1E-7				
Allan Deviation		0.1 s		2E-13	3E-13		Static and benign conditions	
		1 s		4E-13	5E-13			
		10 s		2E-12	4E-12			
		100 s		5E-12	7E-12			
SSB Phase Noise (achieved after 10 minutes warm-up)	$\mathcal{L}(\Delta f)$							
		0.01 Hz		-42	-37	dBc/Hz	Static and benign conditions.	
		0.1 Hz		-91	-87			
		1 Hz		-123	-120			
		10 Hz		-151	-148			
		100 Hz		-162	-160			
		1 KHz		-170	-168			
		10 KHz		-172	-170			
		100 KHz		-172	-170			
Retrace		After 30 minutes			± 2			ppb
G-sensitivity		Gamma 3 directions			± 1.0	ppb/G		
Input Voltage	V _{cc}		4.75	5.0	5.25	V		
Power consumption, Still air	P	steady state, 25°C		1.4	1.7	W	Still air	
		start-up @ -30°C		4.0	4.5			
Spectral Purity		Subharmonics		none		dBc	Produced by device, not set-up related	
		Spurious			-135			
		Harmonics		-35	-30			
Load	AC-coupled 50 Ohm (Sine-wave)							
Warm-up time	τ	to 0.1ppm accuracy		3	5	minutes		
Cold Start	Must start at -40°C with about 10 MHz frequency and about +14 dBm Output Power							
Output Waveform	Sine-wave							
Output Power			+13	+14	+15	dBm	Option N	
			+9	+10	+11		Option R	
Control voltage	V _c		0		10.0	V	L slope P slope	
			0		V _{ref}			
Input impedance	Z _{in}	At V _c pin	10			KOhm	L slope	
Modulation bandwidth	F _m		DC		1	KHz	L slope	
Reference Voltage	V _{ref}			4.096		V	P slope only	
Output Impedance		At V _{ref} pin		100		Ohm		
Pull range		from nominal F	± 0.3	± 0.4		ppm	L slope, P slope	
Deviation slope		Monotonic, positive		0.1		ppm/V	L slope P slope	
				0.2				



Setability	Vc0	@25°C, Fnom.	4.096 ±0.5 2.048 ±0.25	V V	L slope P slope
Initial calibration	ΔF/F			±70 ppb	No Vc Function

Notes:

- 1*. Longer storage time, especially at low temperatures, may affect both retrace and setability parameters. It may require few days on power for re-stabilization.
- 2*. All parameters, unless otherwise specified, are guaranteed over specified temperature and Vcc range. The tests of phase noise and short-term stability, however, are performed at room temperature in benign and static environment only.
- 3*. It is highly recommended, if possible, to avoid tuning the calibration externally in order to avoid deteriorating the phase noise and short-term stability performance. If necessary, metal film low noise resistors with bias from Vref port must be used.
- 4*. If No Vc option is selected, pin #1 is not connected. Initial calibration in this case will be ± 50 ppb MAX, ±25 ppb TYP as shipped.
- 5*. Frequency jumps < 300E-12 (1 s gate time on the counter) guaranteed, not tested.
- 6. Vc internal bias 4.096V for L slope, 2.048V for P slope.
- 7*. Height code 6 by special requirement only, consult NEL.

Environmental and Mechanical

Operating temp. range	0°C to 70°C Standard, Other options – see chart below
Storage Temperature	-50°C to 90°C
Mechanical Shock	Per MIL-STD-202, 30G, 11ms
Vibration	Per MIL-STD-202, 5G to 2000 Hz
Soldering Conditions	260°C for 10s Max leads only

Electrical Connections

Pin Out	Pin #1-Vc or N/C ; Pin#2 – Vref (P slope only)/NC ; Pin #3 – Vcc; Pin #4- Output ; Pin #5- GND;
----------------	---



Creating a Part Number

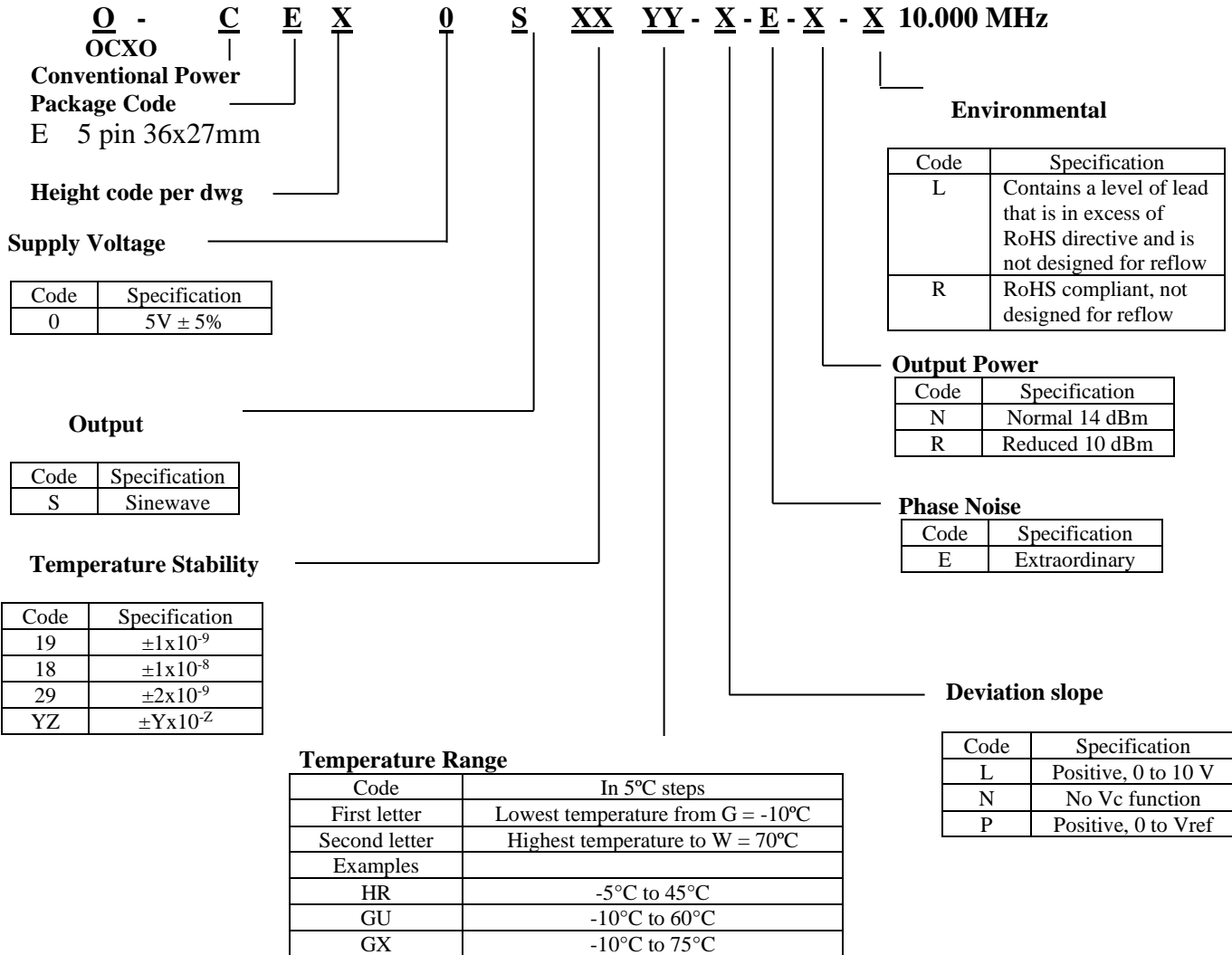

*Not all combinations are available. Consult Factory.

7*Temperature Code Table

Letter	Temp °C	Letter	Temp °C	Letter	Temp °C	Letter	Temp °C	Letter	Temp °C	Letter	Temp °C
A	-40	F	-15	K	10	P	35	U	60	Z	85
B	-35	G	-10	L	15	Q	40	V	65		
C	-30	H	-5	M	20	R	45	W	70		
D	-25	I	0	N	25	S	50	X	75		
E	-20	J	5	O	30	T	55	Y	80		



10 MHz Output Frequency

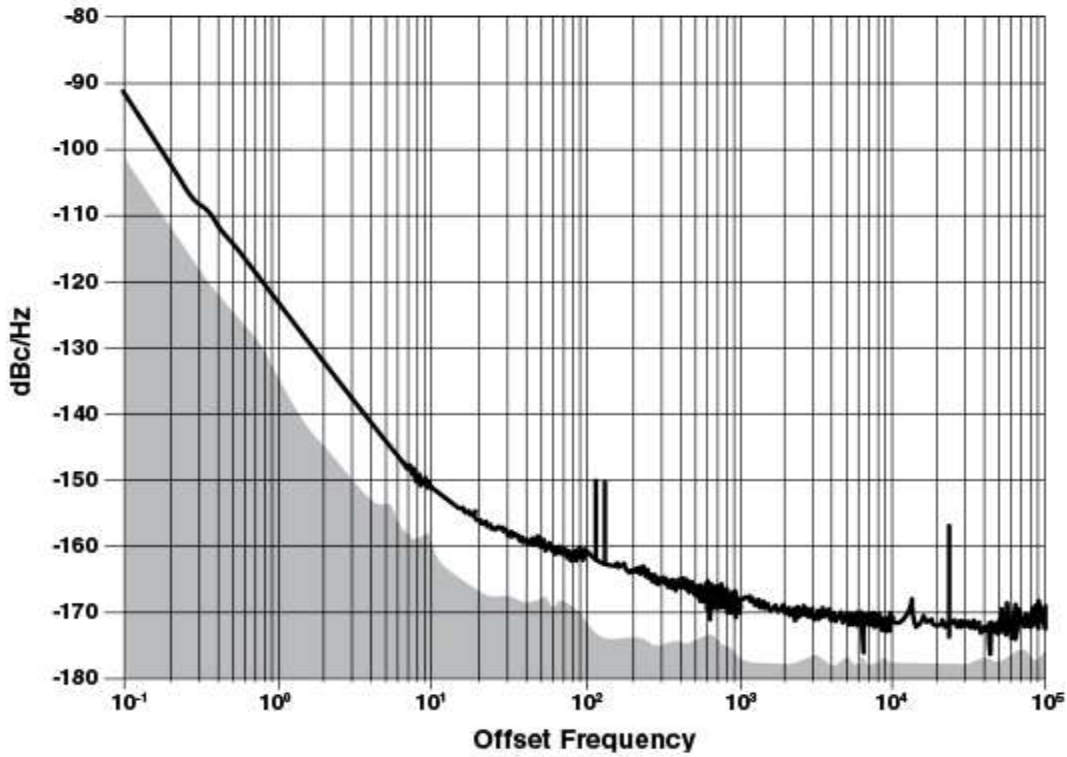

ADEV

